



PACIFIC DISPLAY DEVICES

LCD Component Data Sheet **Model Number: 12232-10**

122 x 32 Dot
Graphic LCD Assembly
With SED1520 Graphics Controller
LED & EL Panel Backlight

CONTENTS

1.	GENERAL INFORMATION	
1.1	Product Overview	2
1.2	Part Options and Numbering System	2
1.3	Absolute Maximum Ratings	3
1.4	Circuit Block Diagram	3
1.5	Mechanical Characteristics	3
1.6	Input Signal Function	4
1.7	LCM Power, Contrast Control and Bias	4
1.8	LCM Dimensions	5
1.9	LCM Schematic	6
1.10	LCM Application Notes	7
2.	ELECTRICAL / OPTICAL CHARACTERISTICS	
2.1	DC Electrical Characteristics	8
2.2	AC Electrical Characteristics	9
2.3	Optical Characteristics	10
2.4	LED Backlight Characteristics	12
2.5	EL Panel Backlight Characteristics	12
3.	LCD CONTROLLER CHARACTERISTICS	
3.1	LCD Controller Display and Control Functions (SED 1520)	13
3.2	LCD Controller Display Data Ram Address Map	15
4.	RELIABILITY	16
5.	PRECAUTIONS FOR USING LCD MODULES	17

1. GENERAL INFORMATION

1.1 Product Overview

- 122 x 32 dot matrix LCD
- STN (Super Twisted Nematic) or FSTN (Film compensated Super Twisted Nematic) Technology
- SED1520 (or equivalent) Graphics Controller
- Multiplex drive : 1/32 duty, 1/6 bias
- LCD Module Service Life: 100,000 hours minimum

1.2 Part Options and Numbering System

12232	-10	-SL	-F	-ST	-LED	-GY	-6	
-------	-----	-----	----	-----	------	-----	----	--

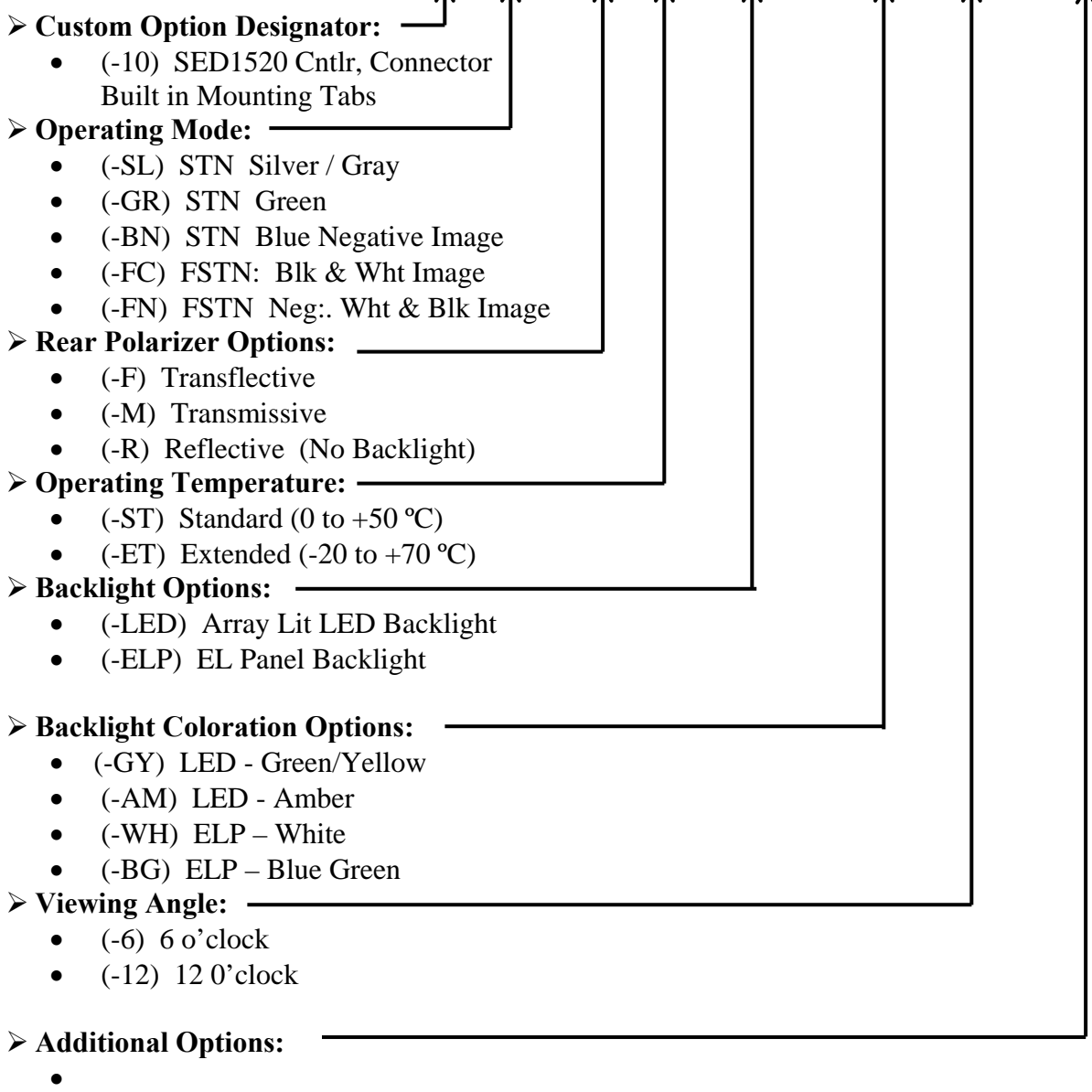

1.3 Absolute Maximum Ratings

Parameter	Symbol	Min	Max	Unit
Supply voltage for logic	$V_{DD} - V_{SS}$	-0.3	6.7	V
Supply voltage for LCD	$V_{DD} - V_O$	-0.3	13.0	V
Input voltage	V_I	-0.3	$V_{DD} + 0.3$	V
Standard Operating temperature	TOP (-ST)	0	50	°C
Standard Storage temperature	TST (-ST)	-10	60	°C
Extended Operating temperature	TOP (-ET)	-20	70	°C
Extended Storage temperature	TST (-ET)	-30	80	°C
Soldering Temp	Tsolder	260		°C

1.4 Circuit Block Diagram

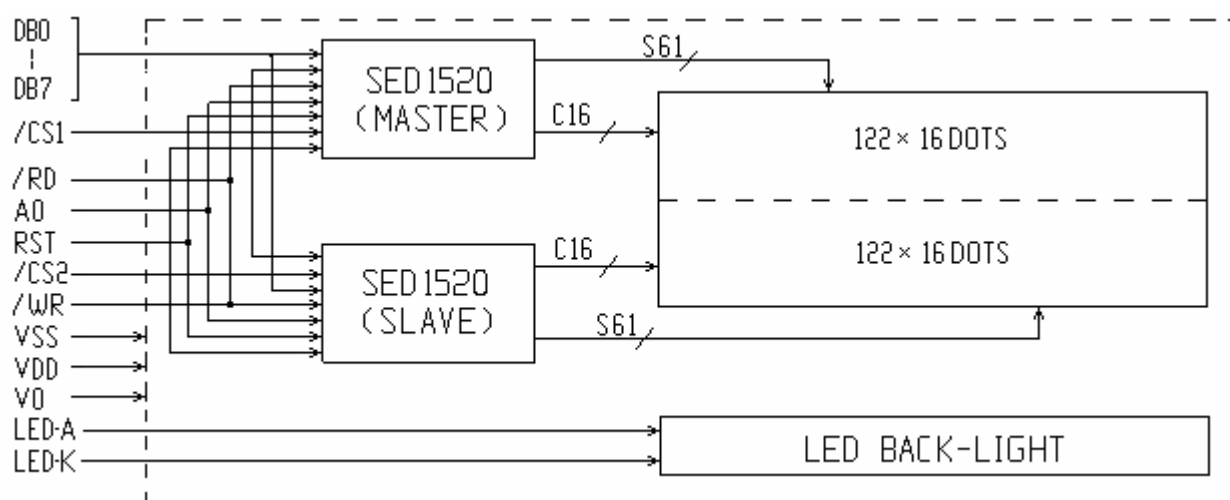

1.5 Mechanical Characteristics

Item	Contents	Unit
Module size (W×H×T)	65.1 x 27.1 x 15.1 Max (All configurations)	mm
Viewing area (W×H)	60.5 x 18.5	mm
Active area (W×H)	53.64 x 15.64	mm
Number of dots	122 x 32	dots
Dot size (W×H)	0.4 x 0.45	mm
Dot pitch (W×H)	0.44 x 0.49	mm

1.6 Input Signal Function

Pin No.	Symbol	Level	Description	Notes*
1	A0	H/L	H : Data signal, L : Instruction signal	
2	/CS1	L	Chip select signal for SED 1520 (Master)	2
3	/CS2	L	Chip select signal for SED 1520 (Slave)	2
4	CL	H/L	2KHz External Clock (-FAA Chip Type)	5
5	/RD	L	L : Read data bus from controller mode Appropriate /CS line must also be active This is the "R/W" line on the 1520	3, 4
6	/WR	L	L : Write data bus to controller mode Appropriate /CS line must also be active This is the "E" line on the 1520	3, 4
7	VSS	0V	Ground	
8	DB0	H/L	Data bit 0	
9	DB1	H/L	Data bit 1	
19	DB2	H/L	Data bit 2	
11	DB3	H/L	Data bit 3	
12	DB4	H/L	Data bit 4	
13	DB5	H/L	Data bit 5	
14	DB6	H/L	Data bit 6	
15	DB7	H/L	Data bit 7	
16	VDD	5.0V	Supply voltage for logic	
17	RES	H → L	Falling Edge Reset – Selects 8080 Interface Must be left "Low" during normal module operation	3
18	VO	---	Input voltage for LCD backplane (Contrast)	1
19	LED-A	4.2V	LED Backlight Anode	
20	LED-K	0V	LED Backlight Cathode	

***Notes:**

- 1) VO is referenced to both VDD and temperature. See table on page 6 for exact value(s).
- 2) "/CS1" & "/CS2" tie to the separate /CS pins on the Master & Slave SED 1520 to be used as the Controller select. The "E" (/WR) line cannot be used as a "E" line in a 6800 implementation since it is common to both controllers.
- 3) This module can only use the 8080 style interface, and it is set by the state of the reset line. Reset occurs when reset line transitions High to Low. Reset line MUST be left in "Low" signal level condition during normal module operation
- 4) If /CS1 & /CS2 are both active (high), and /RD line is set to Read (low), damage can occur to module due to bus contention causing serious over-current conditions.
- 5) External 2KHz clock must be supplied – see SED-1520 data sheet for clock signal requirements

1.7 LCM Power, Contrast Control and Bias

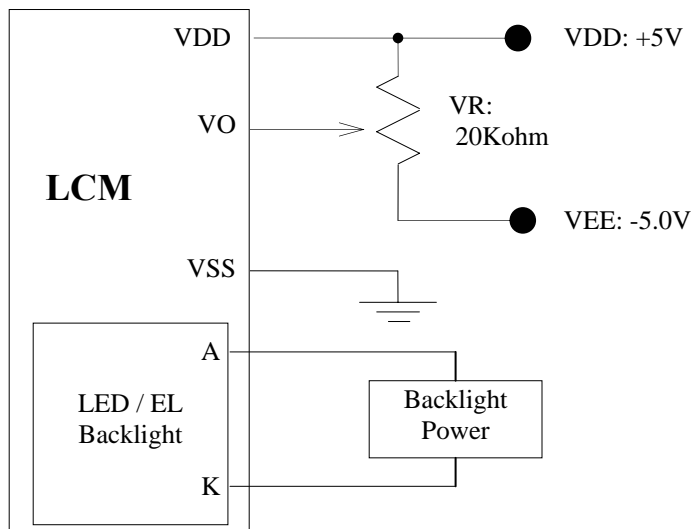

1.8 LCM Dimensions

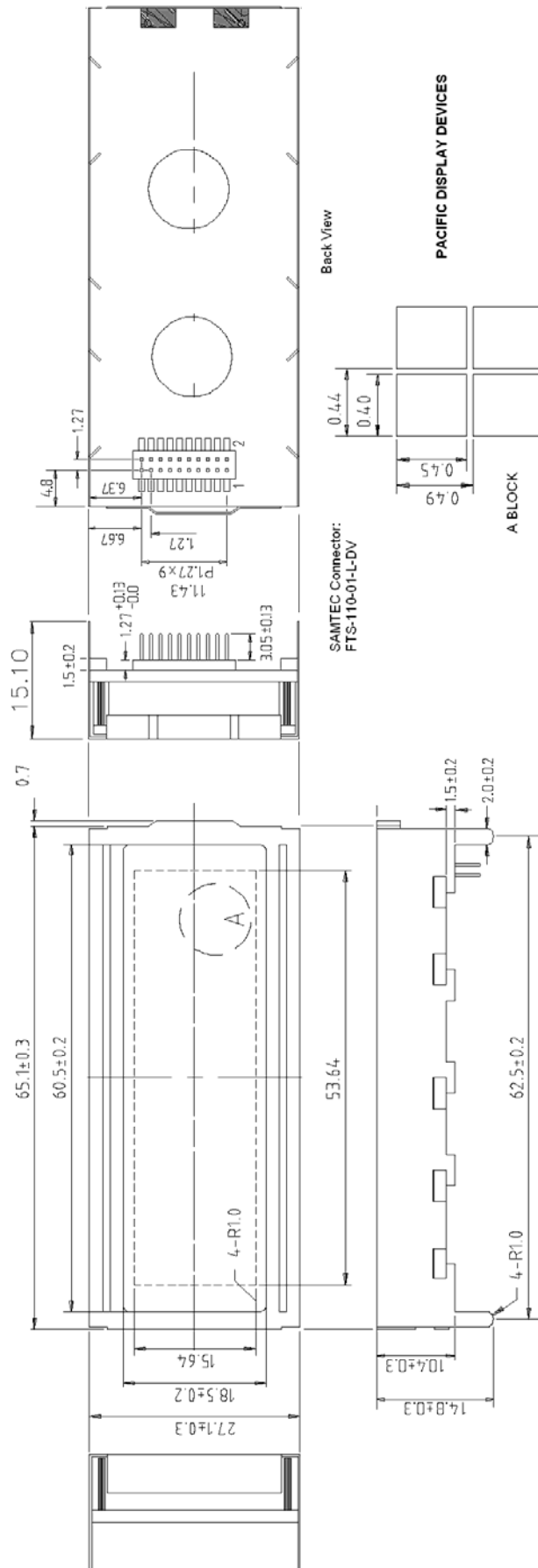

1.9 LCM Schematic

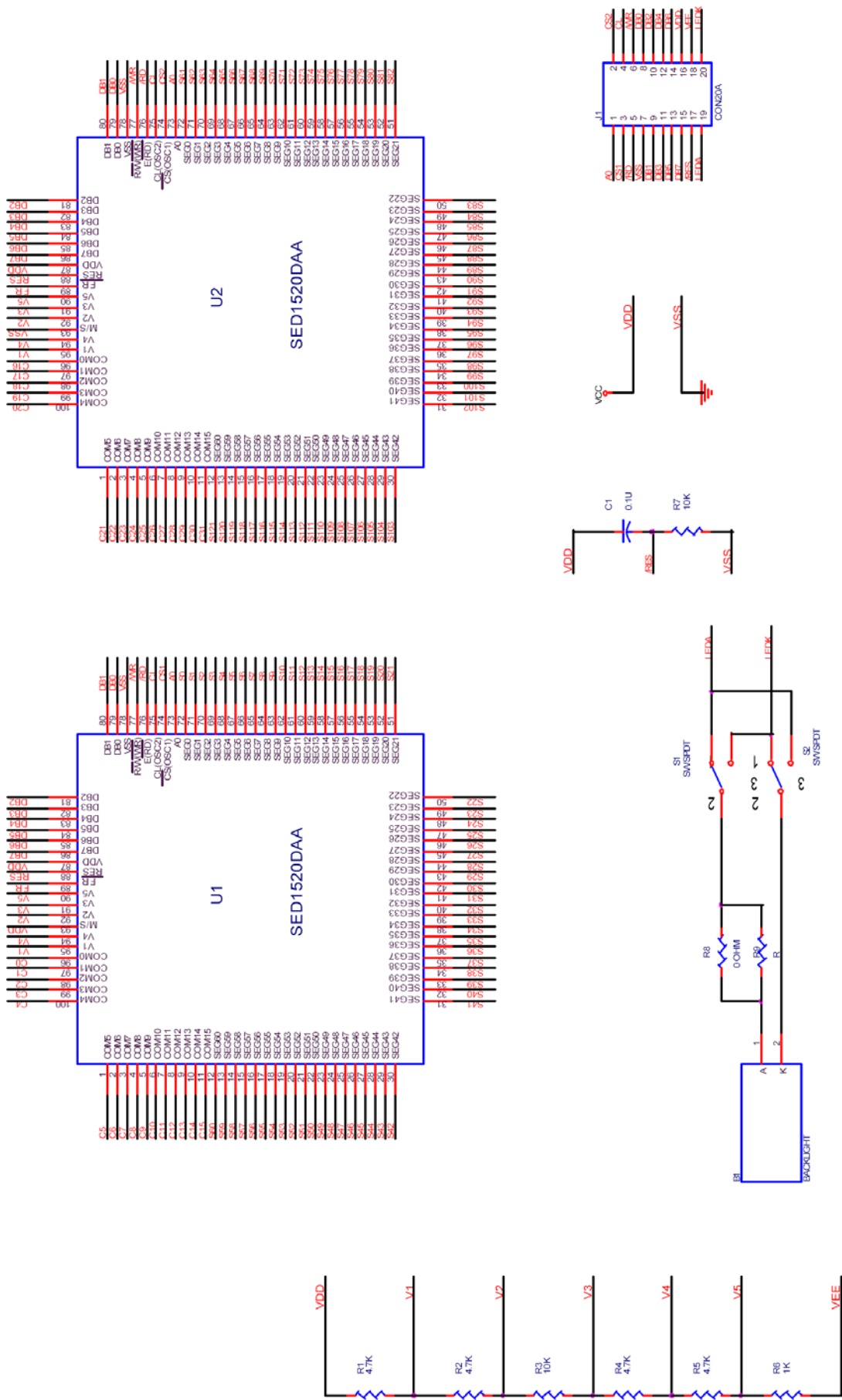

1.10 LCM Application Notes

The Epson SED1520 is used on many Pacific Display Devices GDM 12232 family modules with 122 segments and 32 commons. Extrapolating the information needed to interface to these ICs on the standard module might be a bit difficult from the Epson documentation. Here is a brief that may speed your progress.

Duty Cycle:

Set the Duty to 1/32 (D=1).

Master / Slave Configuration:

The PDD GDM 12232 display family uses the commons from both ICs to form the 32 common rows. Both ICs are used in the active mode. One SED1520 will be hardware configured on the PCB as Master by connecting the M/S pin to Vdd. The other IC will be hardware configured as Slave by connecting the M/S pin to Vss. With the duty set to 1/32 the master will manage the multiplexing for all 32 commons. Addressing the rows on the SED1520 is done by paging. 1 page is 8 bits (or 1 word). The word is written entirely in the same segment (column), but down across 8 commons.

Display Writing Example:

Starting in the upper left of the display (CS1 (Left Side), Page 0 (First 8 commons), Segment 0), write a full word of data. The data will write to the first column on the display on rows 1 to 8. If one repeats this for all 61 segments, the first page will be full on the left side of the panel. The segment addresses should increment automatically after each write (up till 80), but since there are only 61 segments it will need to be set back to 0 if you are writing in sequence. Apply settings CS1, Page 1, Segment 0 and repeat writing 61 words. Then repeat writing 61 words for CS1 / Page 2 / Segment 0 and CS1 / Page 3 / Segment 0. At this point, the left hand side of the display should be complete. One can repeat the process substituting CS2 (Right Side).

2. ELECTRICAL / OPTICAL CHARACTERISTICS

2.1 DC Electrical Characteristics

Parameter	Symbol	Condition	Min	Typ	Max	Unit
Supply voltage for logic	V_{DD}	---	2.7	5.0	5.5	V
Supply current for logic	I_{DD}	---	---	0.3	1.0	mA
Operating voltage for LCD -ST Version	$V_{DD} - V_O$	0°C	---	6.9	---	V
		25°C	---	6.4	---	
		50°C	---	6.0	---	
Operating voltage for LCD -ET Version	$V_{DD} - V_O$	-20°C	---	9.2	---	V
		25°C	---	8.5	---	
		70°C	---	7.8	---	
Input voltage 'H' level	V_{IH}	---	$0.7 V_{DD}$	---	V_{DD}	V
Input voltage 'L' level	V_{IL}	---	0	---	$0.3 V_{DD}$	V

■ TIMING OF POWER SUPPLY

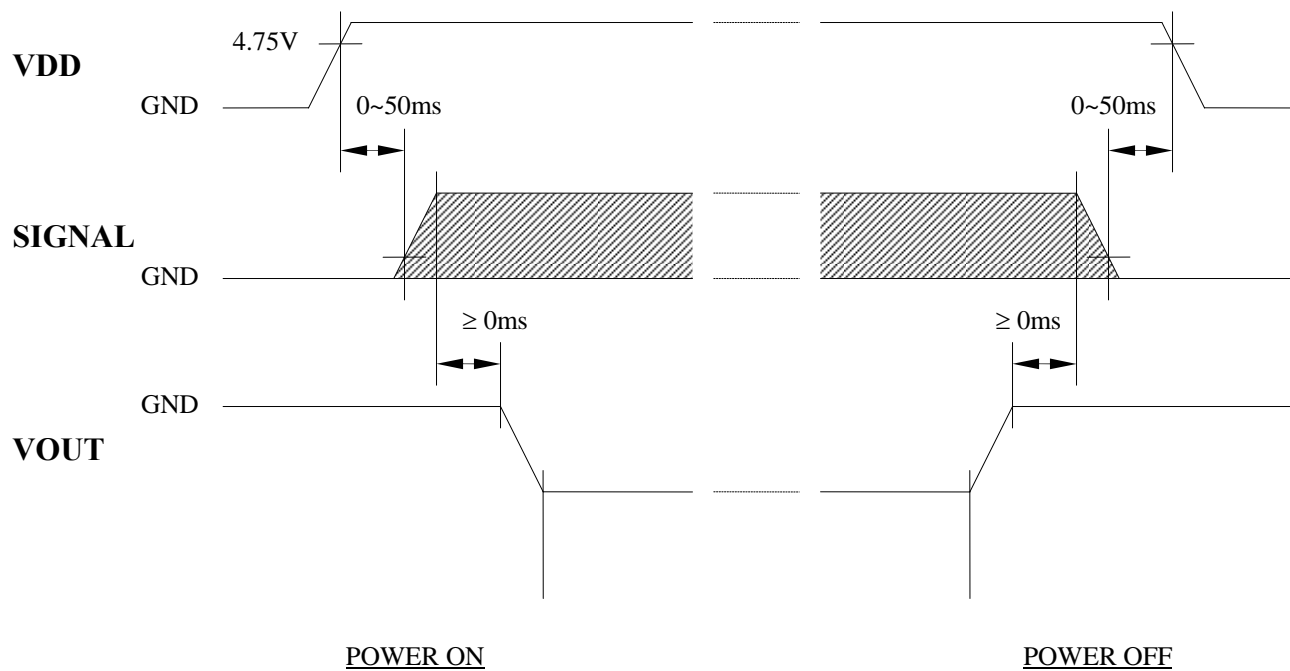

Note : The missing pixels may occur when the LCM is driven except above power supply timing sequence.

2.2 AC Electrical Characteristics

SED 1520 Graphic Controller IC AC Waveform Interface

8080 Family MPU Selected

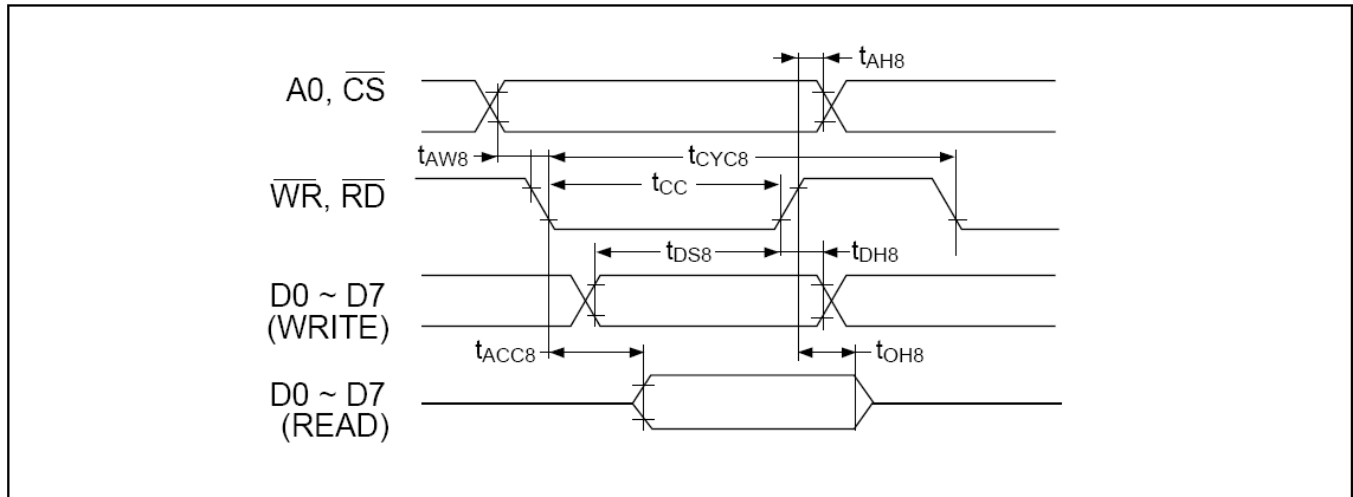

Ta = -20 to 75°C, VSS = -5.0V ± 10%, Unit: ns

Signal	Symbol	Parameter	Min.	Max.	Condition
A0, \overline{CS}	t AH8	Address hold time	10		
	t AW8	Address setup time	20		
\overline{WR} , \overline{RD}	t CYC8	System cycle time	1000		
	t CC	Control pulse width	200		
D0-D7	t DS8	Data setup time	80		
	t DH8	Data hold time	10		
	t ACC8	\overline{RD} access time		90	
	t OH8	Output disable time	10	60	
					CL = 100pF

*1. Each of the values where VSS = -3.0V is about 200% of that where VSS = -5.0V (i.e., the listed value).

*2. The rise or fall time of input signals should be less than 15 ns.

2.3 Optical Characteristics ($V_{OP} = 6.4V, T_a = 25^{\circ}C$)

Item	Symbol	Condition	Min	Typ	Max	Unit
Contrast ratio	Cr	$\theta=0^{\circ}$ $\phi=0^{\circ}$	3	4	---	---
Frame Frequency	f_{FRM}	---	---	60	100	Hz
Viewing angle range	θ_1	25°C	0	---	40	deg
	θ_2		-30	---	30	deg
Response time	T_{on}	25°C	---	120	240	ms
	T_{off}		---	200	350	ms

Definition of angles ϕ and θ :

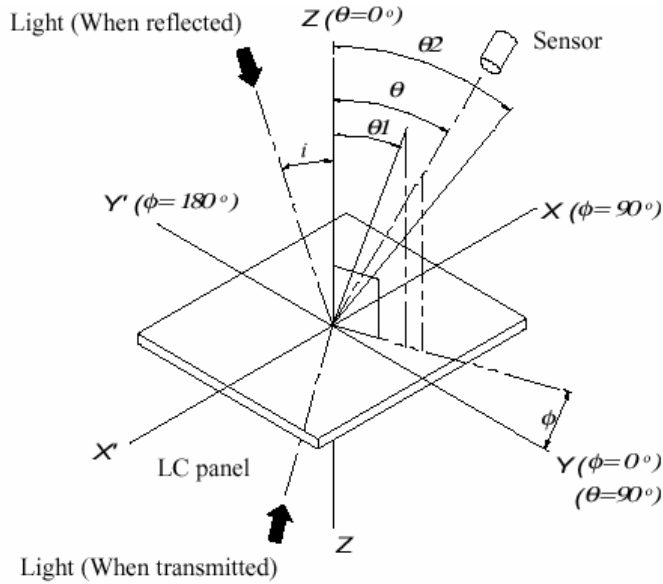

*Definition of contrast C

$$C = \frac{B1}{B2} = \frac{\text{Brightness of selected portion}}{\text{Brightness of unselected portion}}$$

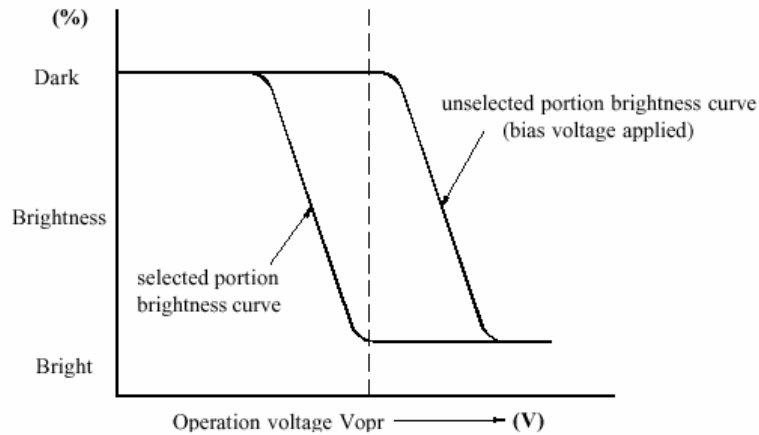

***Definition of viewing angles θ_1 and θ_2**

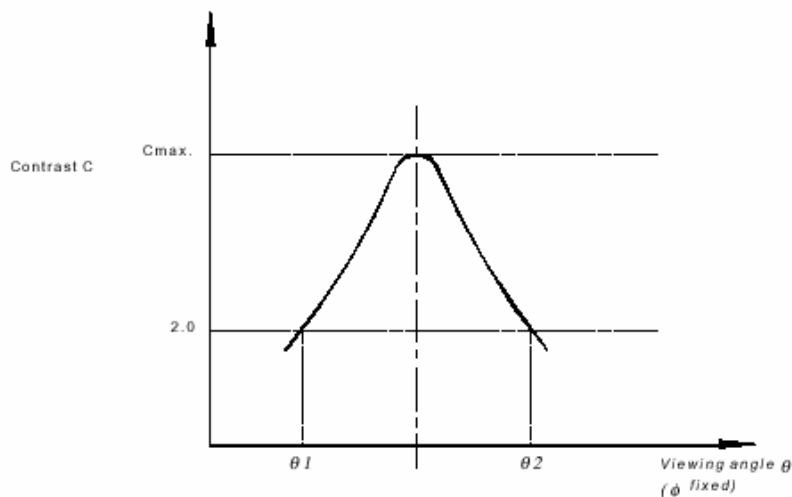

Note : Optimum vision with the naked eye and viewing angle θ at C_{max} above are not always the same.

***Definition of response time**

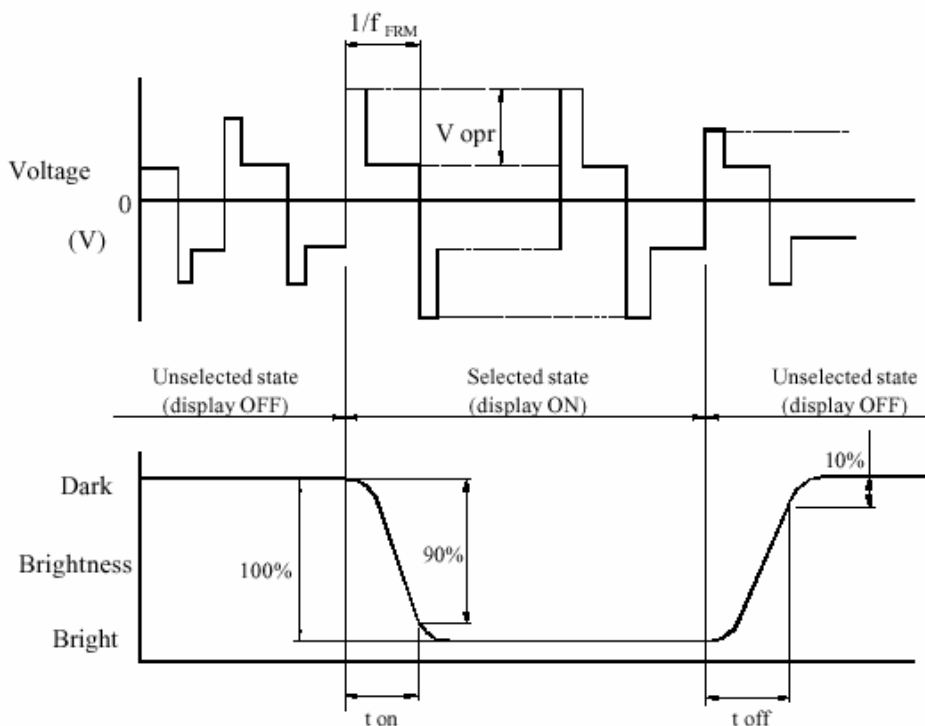

V_{opr} : Operating voltage (V)

t_{on} : Response time (rise) (ms)

f_{FRM} : Frame frequency (Hz)

t_{off} : Response time (fall) (ms)

2.4 LED Backlight Characteristics

■ Yellow-Green LED Operating Characteristics (Array Lit)

Item	Symbol	Conditions	Standard			Unit
			Min.	Typ.	Max.	
Forward voltage	V_f	---	3.9	4.1	4.3	VDC
Forward Current	I_F	---	---	130	300	mA
Reverse Voltage	V_R	---	---	---	8	V

Item	Conditions	Standard		Unit
		Min.	Max.	
Life	Ta= 25 °C	100,000	---	hrs

2.5 EL Panel Backlight Characteristics (Blue-Green)

■ Blue-Green EL Panel Operating Characteristics:

Item	Conditions	Standard			Unit
		Min.	Typ.	Max.	
Current Consumption	100VAC RMS, 400Hz Ta: 25°C	---	2.4	3.6	mA
EL Drive Voltage	---	---	100	150	VAC RMS
EL Drive Frequency	---	---	400	1000	Hz
Operating Temperature	---	-35°C	---	+50°C	°C
Storage Temperature	---	-40°C	---	+60°C	°C
Luminance	100VAC RMS, 400Hz	40	50	---	cd/m ²
Luminance Half-Life	Ta: 25°C	3500	---	---	Hrs

*Note: half life is defined as Luminance being reduced by 50%

3. OPERATING PRINCIPALS AND METHODS

3.1 LCD Controller Display and Control Functions (SED1520 Controller)

Command	R/W	A0	DB7	DB6	DB5	DB4	DB3	DB2	DB1	DB0	Function
Display ON/OFF	0	0	1	0	1	0	1	1	1	0/1	Switches the entire display ON or OFF, regardless of the display RAM data or the internal status. 1 : ON , 0 : OFF *1
Display Start Line	0	0	1	1	0	Display Start Address (0 ~ 31)				Determines the line of RAM data to be displayed at the display top line (COM0).	
Page Address Set	0	0	1	0	1	1	1	0	Page (0 ~ 3)		Sets the page of the Display RAM in the Page Address register.
Column Address Set	0	0	0	Column Address (0 ~ 79)							Sets the column of the Display RAM in the Column Address register.
Status Read	1	0	B U S Y	A D D R E S S	O N / O F F	R E S E T	0	0	0	0	Reads status. BUSY 0 : Ready 1 : Busy ADC 0 : Leftward output 1 : Rightward output ON/OFF 0 : Display ON 1 : Display OFF RESET 0 : Normal 1 : Reset
Write Display Data	0	1	Display Data								Writes the data on the data bus to Display RAM. These commands access a previously-specified address of the display RAM, after which the column address is incremented by one.
Read Display Data	1	1	Display Data								Reads the data from the Display RAM onto the data bus. These commands access a previously-specified address of the display RAM, after which the column address is incremented by one.
ADC Select	0	0	1	0	1	0	0	0	0	0/1	Used to reverse the correspondence between the Display RAM column address and segment driver output ports. 0 : Rightward output 1 : Leftward output
Static Drive ON/OFF	0	0	1	0	1	0	0	1	0	0/1	Selects normal display operation or static all-lit drive display operation. 0 : Normal display operation 1 : Static drive (Power save) *1
Duty Select	0	0	1	0	1	0	1	0	0	0/1	Select LCD duty cycle. 1: 1/32 , 0: 1/16
Read Modify Write	0	0	1	1	1	0	0	0	0	0	Increments the column address counter by one only when display data is written but not when it is read.
End	0	0	1	1	1	0	1	1	1	0	Cancels the Ready Modify Write mode.
Reset	0	0	1	1	1	0	0	0	1	0	Resets the Display Start Line to the 1st line in the register. Resets the column address counter to 0 and page address register to 3.

*1. Power Save Mode is entered by selecting static drive in the Display OFF status.

■ Initialization

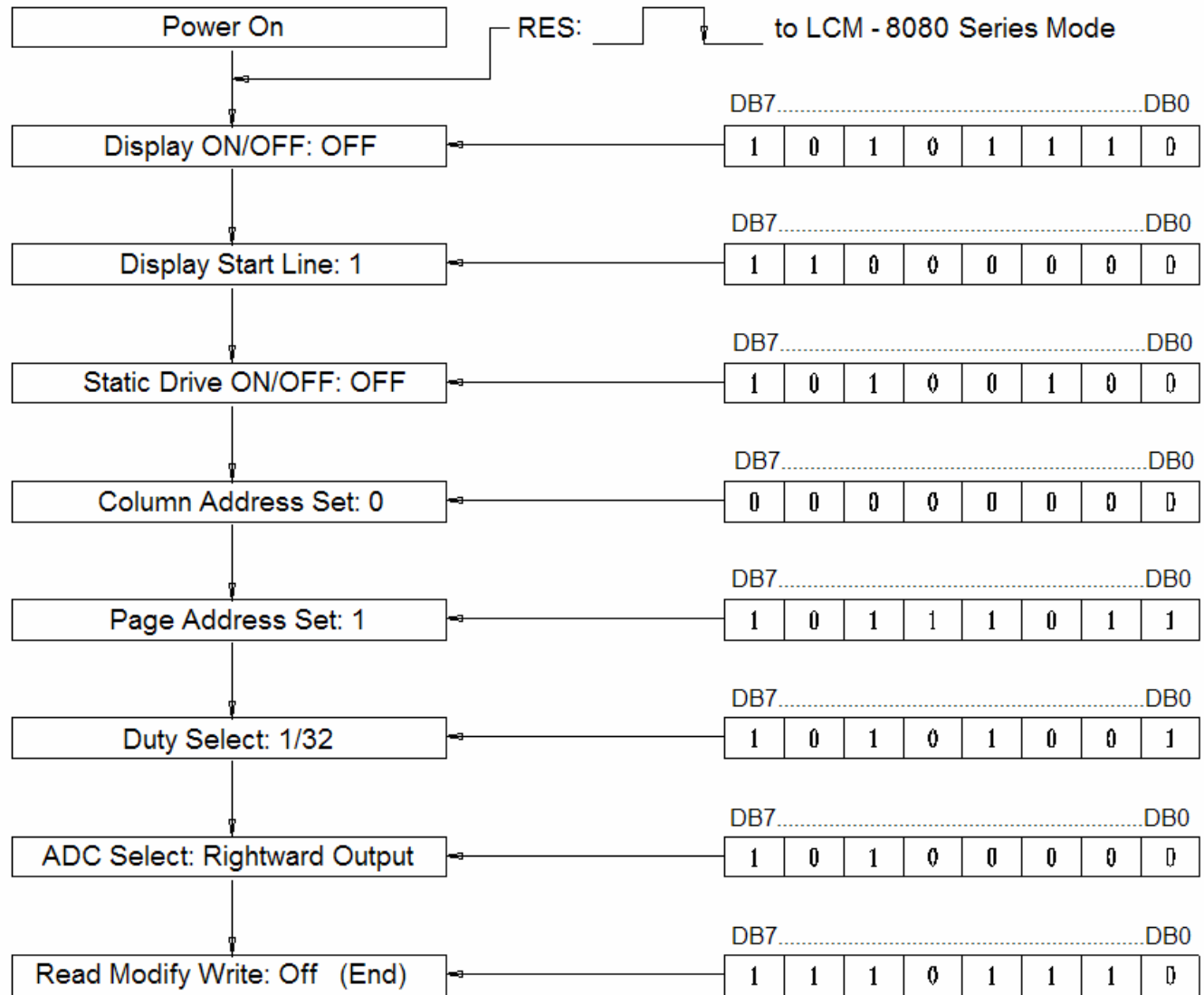

3.2 LCD Controller Display Data Ram Address Map

■ DISPLAY DATA RAM ADDRESS MAP

Page	DATA			Com No.	Driver
2	DB0 ⋮ DB7	1 2 2 X 1 6 P i x e l s		0	Slave
3	DB0 ⋮ DB7			15	
0	DB0 ⋮ DB7	1 2 2 X 1 6 P i x e l s		16	Master
1	DB0 ⋮ DB7			31	
Column Addr.	ADC=0	00 —————→ 3C	00 —————→ 3C		
	Seg No.	0 —————→ 60	0 —————→ 60		
	Driver	Master		Slave	

4. RELIABILITY

Environmental Test				
No	Test Item	Content of Test	Test Condition	Applicable Standard
1	High temperature storage	Endurance test applying the high storage temperature for a long time.	60 °C 200 hrs	-----
2	Low temperature storage	Endurance test applying the low storage temperature for a long time.	-10 °C 200 hrs	-----
3	High temperature operation	Endurance test applying the electric stress (Voltage & Current) and the thermal stress to the element for a long time.	50 °C 200 hrs	-----
4	Low temperature operation	Endurance test applying the electric stress under low temperature for a long time.	0 °C 200 hrs	-----
5	High temperature / Humidity storage	Endurance test applying the high temperature and high humidity storage for a long time.	60 °C , 90 %RH 96 hrs	MIL-202E-103B JIS-C5023
6	High temperature / Humidity operation	Endurance test applying the electric stress (Voltage & Current) and temperature / humidity stress to the element for a long time.	40 °C , 90 %RH 96 hrs	MIL-202E-103B JIS-C5023
7	Temperature cycle	Endurance test applying the low and high temperature cycle. $ \begin{array}{c} -20^{\circ}\text{C} \quad 25^{\circ}\text{C} \quad 70^{\circ}\text{C} \\ 30\text{min} \quad \rightleftharpoons \quad 5\text{min.} \quad \rightleftharpoons \quad 30\text{min} \\ \longleftarrow \hspace{10em} \longrightarrow \\ \text{1 cycle} \end{array} $	-10°C / 60°C 10 cycles	-----
Mechanical Test				
8	Vibration test	Endurance test applying the vibration during transportation and using.	10~22Hz → 1.5mmp-p 22~500Hz → 1.5G Total 0.5hrs	MIL-202E-201A JIS-C5025 JIS-C7022-A-10
9	Shock test	Constructional and mechanical endurance test applying the shock during transportation.	50G Half sign wave 11 msdc 3 times of each direction	MIL-202E-213B
10	Atmospheric pressure test	Endurance test applying the atmospheric pressure during transportation by air.	115 mbar 40 hrs	MIL-202E-105C
Others				
11	Static electricity test	Endurance test applying the electric stress to the terminal.	VS=800V , RS=1.5 kΩ CS=100 pF 1 time	MIL-883B-3015.1

*** Supply voltage for logic system = VDD. Supply voltage for LCD system = Operating voltage at 25°C

■ LCD Panel Service Life

Definition of panel service life

- 100,000 hours minimum at 25° C ±10%
- Contrast becomes 30% of initial value
- Current consumption becomes three times higher than initial value
- Remarkable alignment deterioration occurs in LCD cell layer
- Unusual operation occurs in display functions

5. PRECAUTIONS FOR USING LCD MODULES

Installing LCD Modules

The hole in the printed circuit board is used to fix LCM as shown in the picture below. Attend to the following items when installing the LCM.

- 1) Cover the surface with a transparent protective plate to protect the polarizer and LC cell.

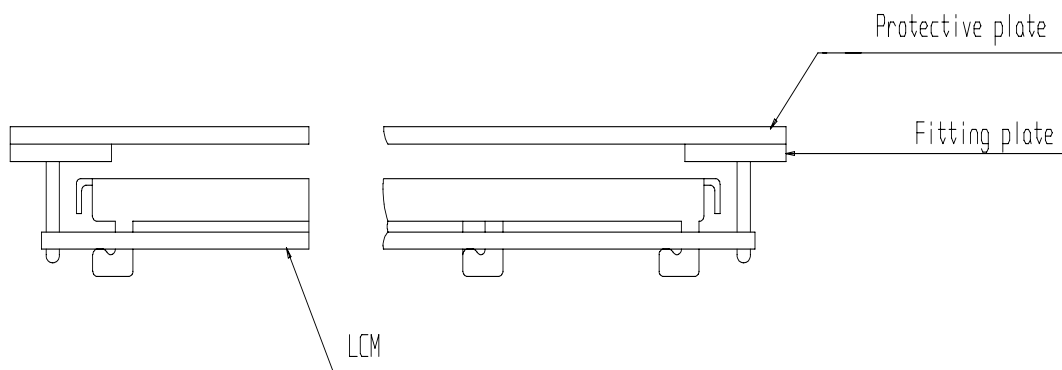

- 2) When assembling the LCM into other equipment, the spacer to the bit between the LCM and the fitting plate should have enough height to avoid causing stress to the module surface, refer to the individual specifications for measurements. The measurement tolerance should be ± 0.1 mm.

Precaution for Handling LCD Modules

Since LCM has been assembled and adjusted with a high degree of precision, avoid applying excessive shocks to the module or making any alterations or modifications to it.

- 1) Cover the surface with a transparent protective plate to protect the polarizer and LC cell.
- 2) Do not alter, modify or change the shape of the tab on the metal frame.
- 3) Do not make extra holes on the printed circuit board, modify its shape or change the positions of components to be attached.
- 4) Do not damage or modify the pattern writing on the printed circuit board.
- 5) Absolutely do not modify the zebra rubber strip (conductive rubber) or heat seal connector.
- 6) Except for soldering the interface, do not make any alterations or modifications with a soldering iron.
- 7) Do not drop, bend or twist LCM.

Electro-Static Discharge Control

Since this module uses a CMOS LSI, the same careful attention should be paid to electrostatic discharge as for an ordinary CMOS IC.

- 1) Make certain that you are grounded when handling LCM.
- 2) Before remove LCM from its packing case or incorporating it into a set, be sure the module and your body have the same electric potential.
- 3) When soldering the terminal of LCM, make certain the AC power source for the soldering iron does not leak.
- 4) When using an electric screwdriver to attach LCM, the screwdriver should be of ground potentiality to minimize as much as possible any transmission of electromagnetic waves produced sparks coming from the commutator of the motor.
- 5) As far as possible make the electric potential of your work clothes and that of the work bench the ground potential.
- 6) To reduce the generation of static electricity be careful that the air in the work is not too dried. A relative humidity of 50%-60% is recommended.

Precaution for soldering to the LCM

- 1) Observe the following when soldering lead wire, connector cable and etc. to the LCM.
 - a) Soldering iron temperature : $280^{\circ}\text{C} \pm 10^{\circ}\text{C}$.
 - b) Soldering time : 3-4 sec.
- 2) Solder : eutectic solder.

- 3) If soldering flux is used, be sure to remove any remaining flux after finishing to soldering operation. (This does not apply in the case of a non-halogen type of flux.) It is recommended that you protect the LCD surface with a cover during soldering to prevent any damage due to flux spatters.
- 4) When soldering the electroluminescent panel and PC board, the panel and board should not be detached more than three times. This maximum number is determined by the temperature and time conditions mentioned above, though there may be some variance depending on the temperature of the soldering iron.
- 5) When remove the electroluminescent panel from the PC board, be sure the solder has completely melted, the soldered pad on the PC board could be damaged.

Precautions for Operation

- 1) Viewing angle varies with the change of liquid crystal driving voltage (VO). Adjust VO to show the best contrast.
- 2) Driving the LCD in the voltage above the limit shortens its life.
- 3) Response time is greatly delayed at temperature below the operating temperature range. However, this does not mean the LCD will be out of the order. It will recover when it returns to the specified temperature range.
- 4) If the display area is pushed hard during operation, the display will become abnormal. However, it will return to normal if it is turned off and then back on.
- 5) Condensation on terminals can cause an electrochemical reaction disrupting the terminal circuit. Therefore, it must be used under the relative condition of 40°C , 50% RH.
- 6) When turning the power on, input each signal after the positive/negative voltage becomes stable.

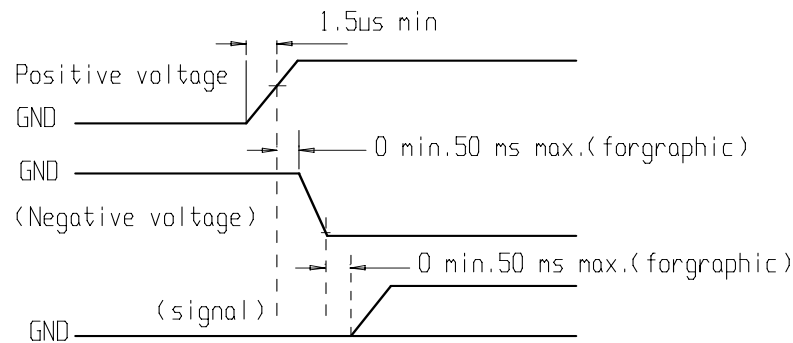

Safety

- If the LCD panel breaks, be careful not to get the liquid crystal in your mouth. If the liquid crystal touches your skin or clothes, wash it off immediately using soap and plenty of water.

Handling

- The display panel is made of glass. Do not subject it to a mechanical shock by dropping it or impact.
- If the display panel is damaged and the liquid crystal substance leaks out, be sure not to get any in your mouth. If the substance contacts your skin or clothes, wash it off using soap and water.
- Do not apply excessive force to the display surface or the adjoining areas since this may cause the color tone to vary.
- The polarizer covering the display surface of the LCD module is soft and easily scratched. Handle this polarizer carefully.
- If the display surface becomes contaminated, breathe on the surface and gently wipe it with a soft dry cloth. If it is heavily contaminated, moisten cloth with one of the following solvents :
 - Isopropyl alcohol
 - Ethyl alcohol
- Solvents other than those above-mentioned may damage the polarizer. Especially, do not use the following.
 - Water
 - Ketone
 - Aromatic solvents
- Exercise care to minimize corrosion of the electrode. Corrosion of the electrodes is accelerated by water droplets, moisture condensation or a current flow in a high-humidity environment.
- Install the LCD Module by using the mounting holes. When mounting the LCD module make sure it is free of twisting, warping and distortion. In particular, do not forcibly pull or bend the I/O cable or the backlight cable.
- Do not attempt to disassemble or process the LCD module.
- NC terminal should be open. Do not connect anything.
- If the logic circuit power is off, do not apply the input signals.

- To prevent destruction of the elements by static electricity, be careful to maintain an optimum work environment.
 - Be sure to ground the body when handling the LCD modules.
 - Tools required for assembling, such as soldering irons, must be properly grounded.
 - To reduce the amount of static electricity generated, do not conduct assembling and other work under dry conditions.
 - The LCD module is coated with a film to protect the display surface. Exercise care when peeling off this protective film since static electricity may be generated.

Storage

- When storing the LCD modules, avoid exposure to direct sunlight or to the light of fluorescent lamps
- Store the module in a dark place where the temperature is $25^{\circ}\text{C} \pm 10^{\circ}\text{C}$ and the humidity below 65% RH.
- Do not store the module near organic solvents or corrosive gases.
- Do not crush, shake, or jolt the module (including accessories).

Cleaning

- Do not wipe the polarizing plate with a dry cloth, as it may scratch the surface.
- Wipe the module gently with soft cloth soaked with a petroleum benzene.
- Do not use ketonic solvents (ketone and acetone) or aromatic solvents (toluene and xylene), as they may damage the polarizing plate.

Others:

- Liquid crystals solidify under low temperature (below the storage temperature range) leading to defective orientation or the generation of air bubbles (black or white). Air bubbles may also be generated if the module is subject to a low temperature.
- If the LCD modules have been operating for a long time showing the same display patterns, the display patterns may remain on the screen as ghost images and a slight contrast irregularity may also appear. A normal operating status can be regained by suspending use for some time. It should be noted that this phenomenon does not adversely affect performance reliability.
- To minimize the performance degradation of the LCD modules resulting from destruction caused by static electricity etc., exercise care to avoid holding the following sections when handling the modules.
 - Exposed area of the printed circuit board.
 - Terminal electrode sections.